



***TWO AXLE
MODULAR TRAILER***

TRA-SV-02





TRA-SV-02

TWO AXLE MODULAR TRAILER

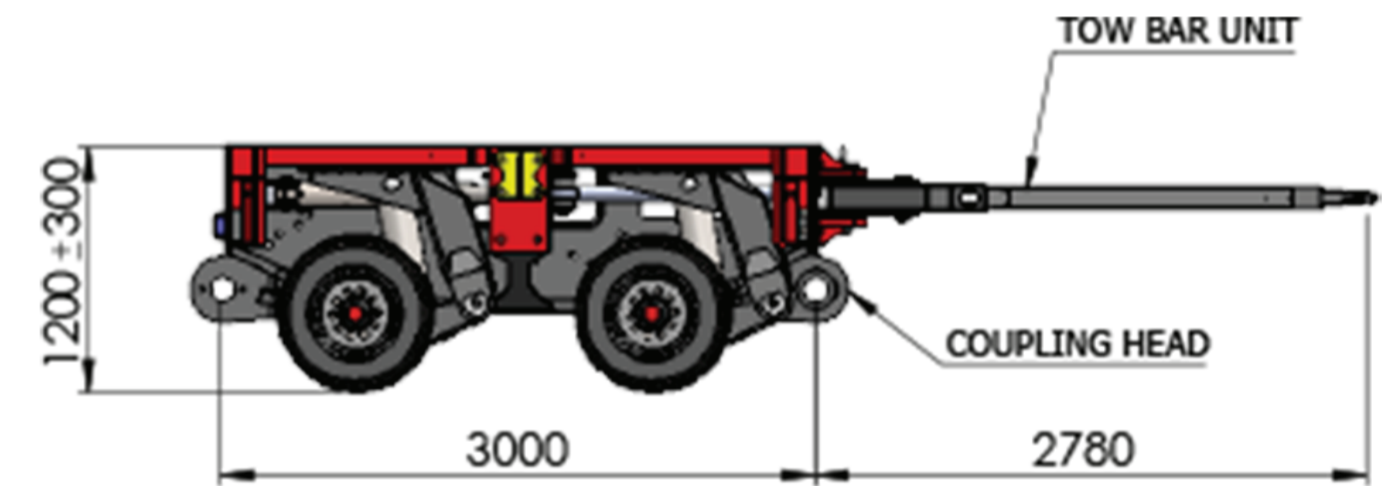
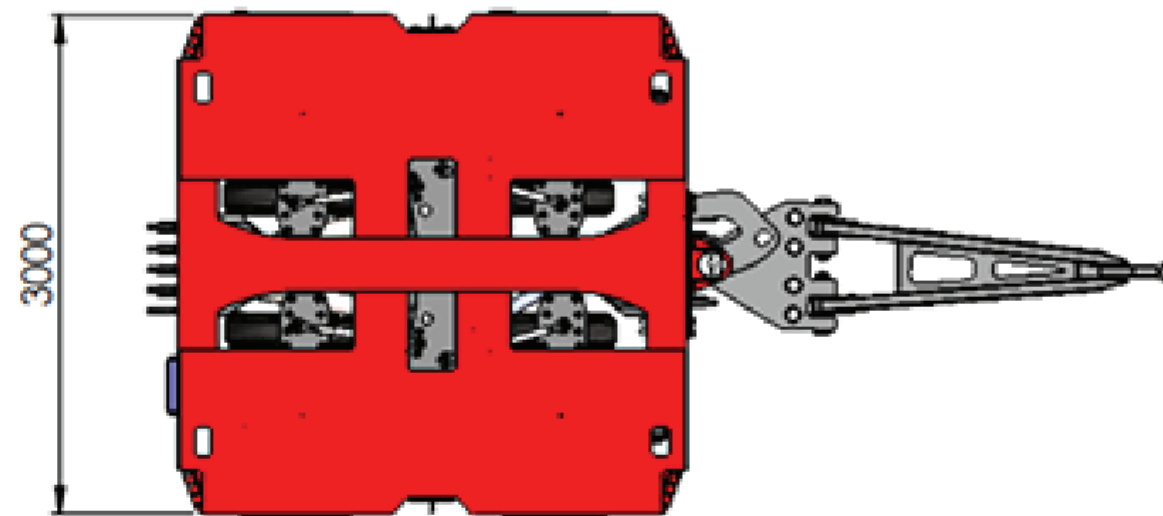
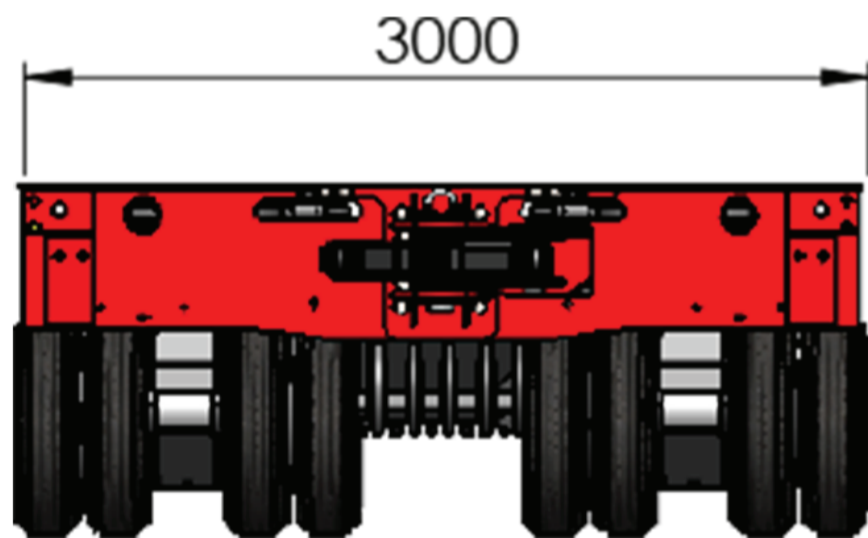

TECHNICAL FEATURES

▶ Gross Vehicle Weight (GVW)	36000 kgs
▶ Dead Weight	7500 kgs ± 2%
▶ Overall Length (Tractor +Trailer)	10076 + 6580 mm
▶ Overall Length (Trailer)	6580 mm ± 100 mm
▶ Platform Length	2970 mm
▶ Tow Bar length	2780 mm ± 50 mm
▶ Overall Width	3000 mm
▶ Overall Height of Trailer	1200 mm ± 300 mm
▶ Axles	RO-8
▶ Number of Axle/Axle Rows	4/2
▶ Axle Load	18000
▶ Max Speed	30 km/h
▶ Size	215/75R17.5
▶ Type	Tubeless
▶ Steering Angle	53°

- ▶ Pioneer manufacturer of modular trailers in India
- ▶ In house complete design setup
- ▶ Designed as per international practices.
- ▶ Standard and custom built accessories available
- ▶ Robust frame made of high tensile alloy steel.

- ▶ High capacity slew rings for easy steering operation
- ▶ Tubeless tyres for weight reduction & good performance
- ▶ High load models are also available
- ▶ Surface protection as per international standards
- ▶ Approved by testing agencies as per AIS 158



Tratec Engineers Pvt Ltd
Damdama Lake Road, Village Bhondsi,
Tehsil Sohna, District Gurugram, Haryana



kirankant@deftec.in
anilnarendra@deftec.in
project@deftec.in



9319426479
9810028268



www.deftec.in
www.tratectrailers.com